

# SERIE E-4000 SPINDLE CON EXPULSION AUTOMATICA DE HERRAMIENTAS

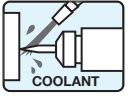

**Product Code**      **AIR QUICK CHANGE SPINDLE NR4040-AQC**      **40,000 rpm**

## Features:

- The collet holder can be replaced by using Air ON/OFF.
- The Spindle housing is made from precision ground, hardened, stainless steel (SUS).
- There are 2 models of collet holders. The collet holder model depends on the collet type selected.  
Various sizes of collets are available.  
(CHK 0.5mm - 6.35mm, CH16 3.0mm, 3.175mm, 4.0mm, 6.0mm, 6.35mm, 8.0mm and 10.0mm)

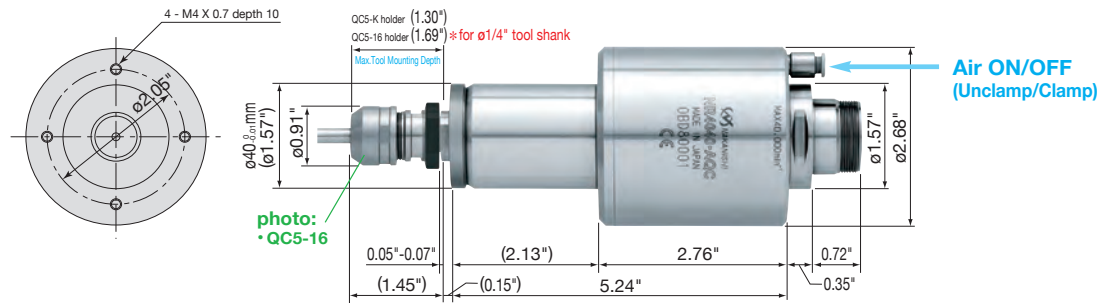
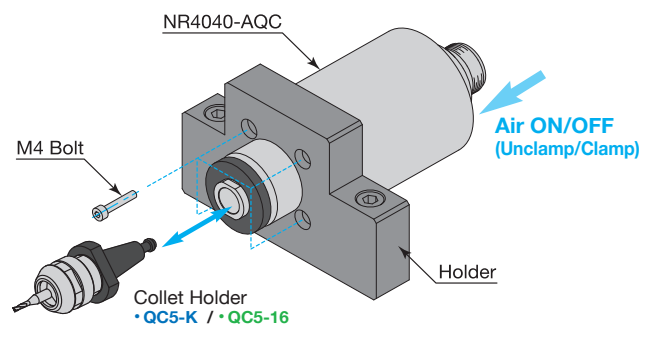

- Allowable Motor Speed ..... 40,000 rpm
- Spindle Accuracy ..... Within 1 μm
- Air for Collet Opening ..... 80~87PSI
- Weight ..... 4 lb. 12.19 oz.

### < Optional >

- Collet Holder ..... **QC5-K**
- Collet (CHK-□□) ..... ø0.5 mm~ø6.35 mm  
(See Page 6-p3 for details)
- Collet Nut (K-265)..... for Collet (CHK)
- Preset Adapter ..... QC5-K ADP
- Wrench ..... 12 x 14 (2 pcs. not included)

### < Optional >

- Collet Holder ..... **QC5-16**
- Collet (CH16-□□□) ..... ø3.0 mm~ø10.0 mm  
(See Page 6-p5 for details)
- Collet Nut (CHN-16) ..... for Collet (CH16)
- Preset Adapter ..... QC5-16 ADP
- Wrench ..... 17 x 22 (2 pcs. not included)

**Note :** Collet and wrenches for collet holder are sold separately.

\*Do not exceed the allowable motor speed for the spindle.

## COLLET HOLDER Taper Shank Tools and Collet Nut

Product	Product Code	Product Name	Collet	Std. Accessories	Attaches to
	9215	• QC5-K	CHK	• Collet Nut (K-265) : 1 pc.	NR4040-AQC NRR4040-QC
	9216	• QC5-16	CH16	• Collet Nut (CHN-16) : 1 pc.	NR4040-AQC NRR4040-QC

## PRESET ADAPTER

Product	Product Code	Product Name
	9217	• QC5-K ADP
	9218	• QC5-16 ADP

